

OIL-X Compressed Air Filters

Grade OVR - Oil Vapour Reduction Filters

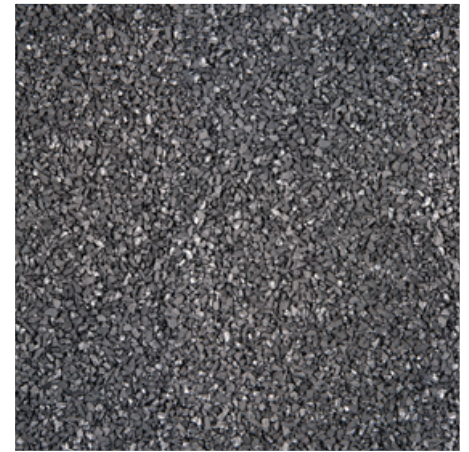

Technically oil free compressed air

When compressed air purity in accordance with ISO8573-1 Class 0 or Class 1 for total oil is required, the Parker domnick hunter OIL-X grade OVR Oil Vapour Reduction filter is an essential component of the compressed air treatment system.

Providing 'Technically Oil Free Compressed Air' from either oil free or oil lubricated compressors, OIL-X grade OVR filters are designed to reduce oil vapour and also overcome the issues of traditional loose filled carbon towers. The loose filled beds of carbon towers offer reduced contact time due to unrestricted air channelling, meaning they are prone to movement of the carbon adsorbent during operation; resulting in degrading performance, attrition of the adsorbent material, high particulate generation and blockage of downstream filters.

Manufactured from extruded aluminium, the Parker domnick hunter OVR is smaller and lighter than equivalent carbon towers. Compact activated carbon cartridges utilise a unique filling technique to maximise packing density of the adsorbent bed. Retained to prevent movement, 100% of the activated carbon bed is then utilised during operation, guaranteeing performance, whilst the heavy attrition, dusting and blocked particulate filters associated with carbon tower designs is eliminated. The use of cartridges also provides trouble free maintenance, reducing system downtime.

Oil free plant air can be affected by many factors such as pressure, temperature, air flow, oil concentration and humidity. The OVR selection process considers all of these factors to ensure consistent outlet air quality over 12 months of continuous operation.

Contact Information

Avilo Stikstof en Persluchtsystemen B.V.

Tel: +31 (0)187 48 13 66
Email: info@avilo.nl



Advantages

- Delivered air quality to ISO8573-1 Class 0 ($\leq 0.003 \text{ mg/m}^3$) or ISO8573-1 Class 1 for total oil - Tested in accordance with ISO8573-5 and 3rd party performance validated by Lloyds Register
- Suitable for use with oil lubricated and oil free compressors - OVR provides 'Technically Oil Free Air' when used in conjunction with Parker OIL-X Grade AO & AA coalescing filters
- Air Quality Guarantee - OVR is matched to all inlet parameters maintaining effective operation for 12 months. Correct sizing ensures seasonal variations in temperature does not affect delivered air quality
- FDA Title 21 compliant & EC1935 exempt - Materials of construction make OVR suitable for use with applications in the food, beverage and pharmaceutical industries
- Plant Scale or application specific oil vapour reduction - Can be installed in the compressor room for plant scale protection, at point of use to protect critical applications (or both if old, contaminated piping is in use)
- Unique adsorbent fill technique - Providing maximum packing density, eliminating dusting, performance degradation and blocked outlet filters
- Simple, easy maintenance - Servicing of OVR is easy as piping can remain in-situ, whilst use of active carbon cartridges offers quick, clean, simple maintenance

Official Parker Distributor

Avilo is a worldwide distributor of parker filtration & separation products. Large Stock. Fast delivery.

Grade OVR Plant Scale / Point of Use Oil Vapour Reduction Filters

Filtration Performance

Filtration Grade	Filter Type	Particle Reduction (inc Water & Oil Aerosols)	Max Remaining Oil Content*	Filtration Efficiency	Initial Dry Differential Pressure	Initial Saturated Differential Pressure	Adsorbent Life	Precede with Grade
OVR	Oil Vapour Reduction	N/A	≤ 0.003 mg/m ³ ≤ 0.003 ppm (w)	N/A	<350 mbar <5 psi	N/A	*12 months	AO + AA

*At system operating temperature and when corrected to match systems conditions.

Technical Data

Filtration Grade	Filter Models	Min Operating Pressure		Max Operating Pressure		Min Operating Temperature		Max Operating Temperature	
		bar g	psi g	bar g	psi g	°C	°F	°C	°F
OVR	P300H - P550I	1	15	16	232	2	35	50	122

Flow Rates

Stated flows are for operation at 7 bar (g) (102 psi g) with reference to 20°C, 1 bar (a), 0% relative water vapour pressure.

Model	Pipe Size	L/s	m ³ /min	m ³ /hr	cfm	Replacement Cartridge	No.	Differential Pressure (OVR Only)							
								100% Flow		75% Flow		50% Flow		25% Flow	
								mbar	psi	mbar	psi	mbar	psi	mbar	psi
OVRP300H <input type="checkbox"/> G <input checked="" type="checkbox"/> XX	2	80	4.8	289	170	P300OVR	1	350	5.1	198	2.9	46	0.7	11	0.2
OVRP350H <input type="checkbox"/> G <input checked="" type="checkbox"/> XX	2	163	9.8	586	345	P350OVR	1	350	5.1	198	2.9	46	0.7	11	0.2
OVRP400I <input type="checkbox"/> G <input checked="" type="checkbox"/> XX	2 ½"	326	19.6	1172	690	P400OVR	1	350	5.1	198	2.9	46	0.7	11	0.2
OVRP450I <input type="checkbox"/> G <input checked="" type="checkbox"/> XX	2 ½"	488	29.4	1758	1035	P450OVR	1	350	5.1	198	2.9	46	0.7	11	0.2
OVRP500I <input type="checkbox"/> G <input checked="" type="checkbox"/> XX	2 ½"	651	39.2	2345	1380	P500OVR	1	350	5.1	198	2.9	46	0.7	11	0.2
OVRP550I <input type="checkbox"/> G <input checked="" type="checkbox"/> XX	2 ½"	814	48.9	2931	1725	P550OVR	1	350	5.1	198	2.9	46	0.7	11	0.2
2 x OVRP550I <input type="checkbox"/> G <input checked="" type="checkbox"/> XX	2 ½"	1629	97.9	5862	3451	P550OVR	2								
3 x OVRP550I <input type="checkbox"/> G <input checked="" type="checkbox"/> XX	2 ½"	2443	146.8	8793	5176	P550OVR	3								
4 x OVRP550I <input type="checkbox"/> G <input checked="" type="checkbox"/> XX	2 ½"	3257	195.8	11724	6901	P550OVR	4								
5 x OVRP550I <input type="checkbox"/> G <input checked="" type="checkbox"/> XX	2 ½"	4071	244.7	14656	8626	P550OVR	5								

Select G for BSPP Threads / Select N for NPT Threads

1 System Information Required for OVR Sizing & Selection

- Minimum pressure at the inlet of the OVR
- Compressor type (oil lubricated or oil free)
- Maximum inlet temperature at the inlet of the OVR (highest summer inlet temp)
- Maximum compressed air flow rate
- Dewpoint of the compressed air (i.e. is the proposed location of the unit before or after a compressed air dryer)
- Oil vapour concentration expected at the inlet of the OVR (default is 0.05 mg/m³)

2 Select correction factors

- For minimum inlet pressure, select a correction factor from the CFIP table that corresponds to the minimum inlet pressure of the compressed air system, remembering to always round down e.g. for 5.3 bar g use the 5 bar g correction factor.
- For maximum inlet temperature there are two tables, one for use with an oil lubricated compressor, the other for oil free compressor. Select a correction factor from the CFIT table for the relevant compressor type, remembering to always round up e.g. for 37 °C use the 40 °C correction factor.
- For pressure dewpoint, select a correction factor from the CFID table.
- For oil vapour concentration, select a correction factor from the CFIV table, remembering to always round up e.g. for 3.25g/m³ use the correction factor for 4mg/m³.

3 Calculate minimum filtration capacity

Minimum filtration Capacity = Compressed Air Flow x CFIT x CFMIP x CFID x CFIV

- Using the minimum filtration capacity, select an OVR model from the flow rate tables.
- The OVR model selected must have a flow rate equal to or greater than the minimum filtration capacity.
- If the minimum filtration capacity exceeds the maximum values of the models shown within the tables, please contact Parker for advice regarding larger multi-banked units.

Correction Factors Inlet Temperature (CFIT)

Oil lubricated compressors		
°C	°F	Correction Factor
25	77	1.00
30	86	1.00
35	95	1.00
40	104	1.25
45	113	1.55
50	122	1.90

Correction Factors Inlet Temperature (CFIT)

Oil free compressors		
°C	°F	Correction Factor
25	77	1.00
30	86	1.00
35	95	1.00
40	104	1.02
45	113	1.04
50	122	1.05

Correction Factor Minimum Inlet Pressure (CFMIP)

Minimum Inlet Pressure	bar g	3	4	5	6	7	8	9	10	11	12	13	14	15	16
	psi g	44	58	73	87	100	116	131	145	160	174	189	203	218	232
Correction Factor		2.00	1.60	1.33	1.14	1.00	1.00	1.00	1.00	1.00	1.00	1.00	1.00	1.00	1.00

Correction Factor - Dewpoint (CFID)

Installation	Correction Factor
After Dryer	1.00
Before Dryer	4.00

Correction Factor Inlet Vapour Content (CFIV)

Inlet Vapour Concentration mg/m ³	0.05	0.1	0.2	0.3	0.4	0.5	0.6	0.7	0.8	0.9	1.0	2.0	3.0	4.0	5.0
	Correction Factor	1	2	4	6	8	10	12	14	16	18	20	40	60	80

Weight & Dimensions

Models	Height (H)		Width (W)		Depth (D)		Weight	
	mm	ins	mm	ins	mm	ins	kg	lbs
OVRP300	998	39.3	534	21.0	350	13.8	38	84
OVRP350	1062	41.8	538	21.2	550	21.7	67	147
OVRP400	1062	41.8	682	26.9	550	21.7	93	205
OVRP450	1062	41.8	836	32.9	550	21.7	121	267
OVRP500	1062	41.8	1005	39.6	550	21.7	144	318
OVRP550	1062	41.8	1174	46.2	550	21.7	171	377

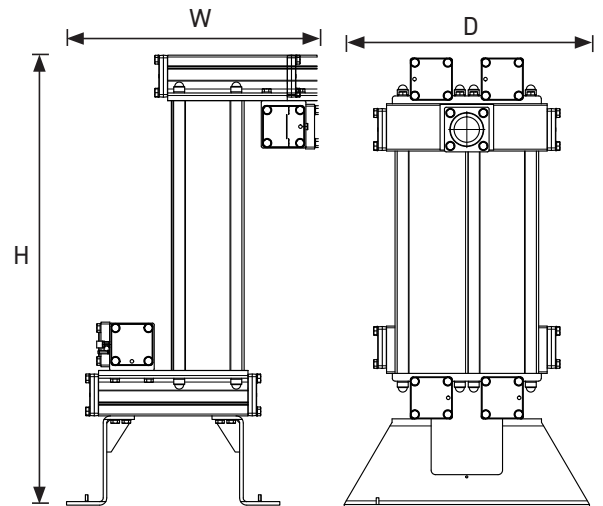

OVRP300 - OVRP550

Filtration Tested In Accordance With

Filtration Grade	OVR
Filter Type	Oil Vapour Reduction
Test Methods Used	ISO8573-5:2001
Oil Vapour Inlet Challenge Concentration	0.05 mg of oil vapour per cubic metre of compressed air

Quality Assurance / IP Rating / Pressure Vessel Approvals

Development / Manufacture	ISO 9001 / ISO 14001
Ingress Protection Rating	Not Applicable
EU	Pressure vessel approved for fluid group 2 in accordance with the Pressure Equipment Directive 2014/68/EU
USA	Approval to ASME VIII Div. 1 not required
AUS	Approval to AS1210 not required
GUS	TR (formerly GOST-R)

For use with Compressed Air & N₂